

# Pacific Electric Chain Hoists

The Pacific Electric Chain Hoists offer a great balance between quality and price. The models vary from 250kg to 2 tonne capacity and are all tested to the Australian standards. All hoists are inclusive of many features which makes them suited for most applications. Optional Motorised Trolleys are available to complete the package.

## Features

- **All Pacific** models are manufactured to comply with AS1418.2.
- **IP65 pendant** with 24 volt control for operator safety.
- **Overload protection** clutch prevents damage caused by overloading.
- **Inclusive of DC Brake** which automatically engages in the event of a power failure.
- **Completely** enclosed design to withstand harsh conditions.
- **Upper and lower** electrical limit switches.
- **Grade 80 zinc plated** load chain supplied as standard.
- **Motor thermal protection** on all Pacific Electric Chain Hoists.
- **Fuse protection** provided for both primary and secondary control circuits.
- **IP54 protection** rating on all electric hoists and trolleys.
- **Reverse phase** protection relay on all models excluding 250kg.
- **Optional radio** remote control.



The information shown is to be used as a guide only. Specifications are subject to change without notice. All materials handling or lifting jobs should be assessed individually. Pacific Hoists products are NOT to be used for lifting or lowering persons.



## Specifications

### Hoists

#### Pacific Electric Chain Hoists - 415Volt, 50Hz

Model	PEH025	PEH050	PEH100	PEH200
Stock Code	PEH025	PEH050	PEH100	PEH200
Rated Capacity (kg)	250	500	1000	2000
Standard Lift Height (m)	3	3	3	3
Chain Dimension (mm)	4 X 12	6.3 X 19.1	7.1 X 20.2	7.1 X 20.2
Speed (m/min)	12/3	10/2.5	8/2	4/1
Motor (kW)	0.6 / 0.15	1.1 / 0.28	1.5 / 0.37	1.5 / 0.37
E.D Rating (%)	40 / 20	40 / 20	40 / 20	40 / 20
Load Chain Fall No.	1	1	1	2
Weight (kg)	30	42	57	62

#### Motorised Trolleys - 415Volt, 50Hz

Model	PET050	PET100	PET200	PET055	PET105	PET205
Stock Code	PET050	PET100	PET200	PET055	PET105	PET205
Rated Capacity (kg)	500	1000	2000	500	1000	2000
Speed (m/min)	10	10	10	20 / 5	20 / 5	20 / 5
Motor (kW)	0.12	0.18	0.37	0.12 / 0.03	0.18 / 0.04	0.37 / 0.09

\*Standard beam sizes available up to 300mm width. Larger sizes available upon request.

The information shown is to be used as a guide only. Specifications are subject to change without notice. All materials handling or lifting jobs should be assessed individually. Pacific Hoists products are NOT to be used for lifting or lowering persons.



## Dimensions (in mm)

### Pacific Electric Chain Hoists

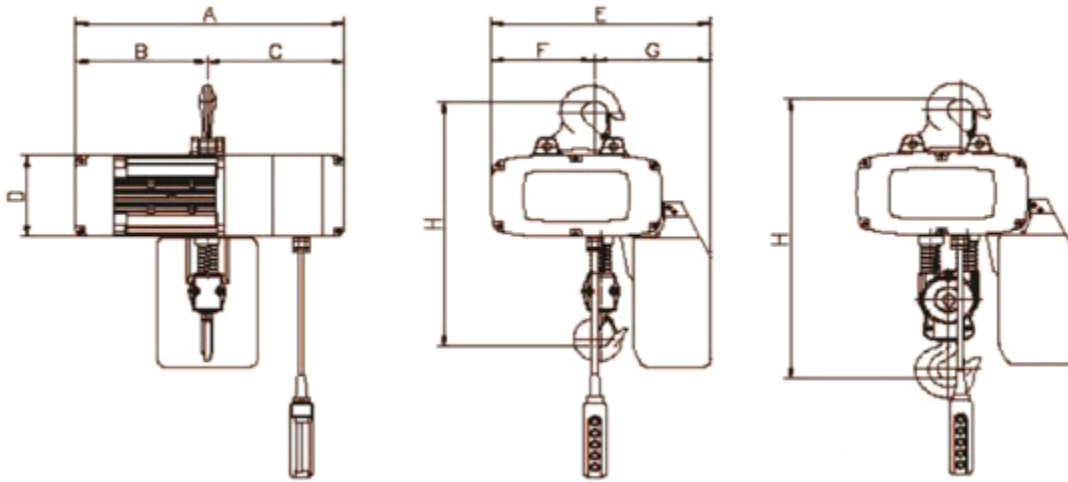

Model	PEH025	PEH050	PEH100	PEH200
A	380	468	487	487
B	175	221	240	240
C	205	247	248	248
D	135	156	170	170
E	299	366	398	398
F	143	186	188	188
G	156	180	210	210
H	376	485	520	592

The information shown is to be used as a guide only. Specifications are subject to change without notice. All materials handling or lifting jobs should be assessed individually. Pacific Hoists products are NOT to be used for lifting or lowering persons.



Pacific Electric Chain Hoists plus Trolley

Hoists

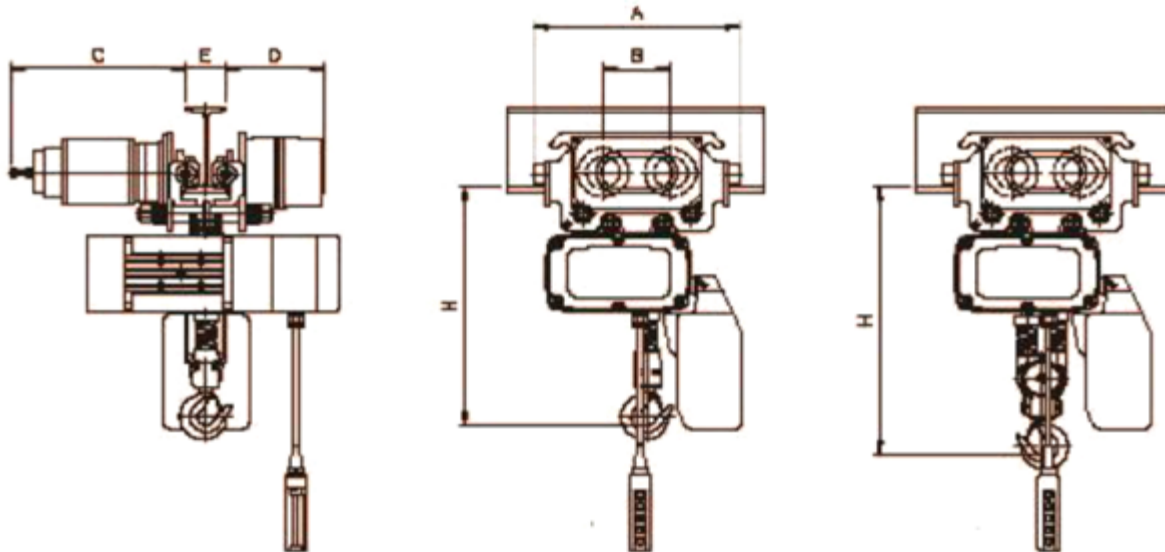

Model	PEH025 + PEH055	PEH050 + PET050	PEH100 + PET105	PEH200 + PET205
A	382	382	382	392
B	125.5	125.5	125.5	159
C	324	324	324	357
D	180	180	180	183
E	75 - 125	75 - 125	75 - 125	100 - 150
H	385	483	510	582

The information shown is to be used as a guide only. Specifications are subject to change without notice. All materials handling or lifting jobs should be assessed individually. Pacific Hoists products are NOT to be used for lifting or lowering persons.



“We have the right product, at the right price, when you need it, on-time, every time”